



IPC-TM-650 TEST METHODS MANUAL

1.0 Scope

1.1 To determine the effect on the connector of the stresses produced by transient acceleration or deceleration forces resulting from handling, transportation, or field operation.

2.0 Reference Documents

2.1 Information in this section is intended to parallel the test method described in EIA-RS-364/TP-27.

3.0 Test Specimen

3.1 A connector (plug and receptacle) complete with applicable guide, keying, and engaging hardware or a card-edge receptacle and mating nominal-thickness printed circuit board.

3.2 Mounting and Termination

3.2.1 **Right Angle, Two-Piece Connector** The receptacle shall be mounted and terminated normally during this test; receptacles designed for mounting on non-rigid bases (e.g., motherboards, metal-plate back panels, etc.) shall be mounted on the smallest section of such a base that will accommodate the test specimen. The plug shall be terminated normally during the test and shall be mounted on a nominal-thickness printed circuit board extending the full width of the plug; the board shall extend a minimum of four inches from the receptacle when the connector is mated.

3.2.2 **Card-Edge Receptacle** The receptacle shall be mounted and terminated normally during this test (see 3.2.1). The mating printed circuit board shall extend the full width of the receptacle and shall extend a minimum of four inches from the receptacle when mated.

3.2.3 **Parallel, Two-Piece Connector** The receptacle and plug shall be terminated normally during this test; both components shall be mounted on nominal-thickness printed circuit boards extending the full width of each. The printed circuit boards shall extend a minimum of four inches from each component when the connector is mated.

Number 3.8	
Subject Mechanical Shock, Connectors	
Date 7/75	Revision A
Originating Task Group N/A	

3.3 Fixturing

3.3.1 **Right Angle Connector** The test specimen shall be held in an adequate resonant free fixture. (Figure 1, Reference Example.)

3.3.2 **Parallel Connector** The test specimen shall be held in an adequate resonant free fixture. (Figure 2, Reference Example.)

3.4 The connector shall be wire (or printed circuit boards) designed such that a continuous electrical circuit (comprising all contacts in series) is formed when the plug (or board) and receptacle are mated.

4.0 Apparatus

4.1 A shock machine capable of producing the specified input shock pulse as shown in Figures 3 and 4. The machine may be of a free- or accelerated-fall, resilient rebound, non-resilient, hydraulic or pneumatic actuated, or other type.

4.2 A shock measurement system consisting of an acceleration sensitive transducer (accelerometer) and appropriate impedance matching, amplifying and recording instrumentation. The entire system shall exhibit a frequency response within the limits shown in Figure 5.

4.2.1 A piezoelectric accelerometer used as the transducer shall have a minimum fundamental resonant frequency of 14 KHz (a resonant frequency >30 KHz is recommended). For suitable low frequency response, the RC time constant of the accelerometer and its load shall be

$$RC > 0.2 \text{ where: } R - \text{load resistance (ohms)}$$

$$C - \text{accelerometer capacitance, plus shunt capacitance of the load and the inter-connecting cable (farads)}$$

4.2.2 A strain gage accelerometer used as the transducer shall have a minimum undamped natural frequency >1500 Hz, with damping from 0.64 to 0.70 of critical.

IPC-TM-650		
Number 3.8	Subject Mechanical Shock, Connectors	Date 7/75
Revision A		

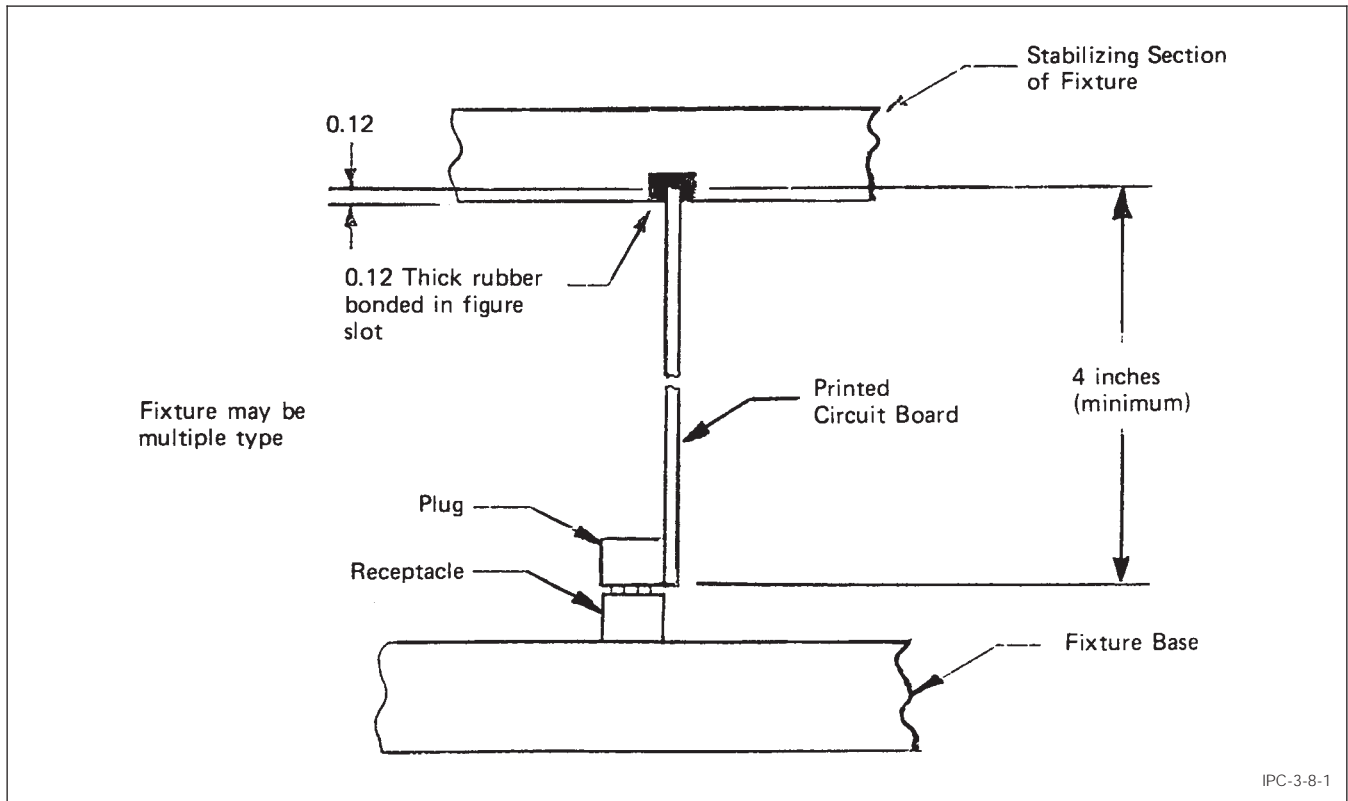

Figure 1 Right Angle Connector Fixture (Suggested)

4.3 A circuit monitor capable of supplying a continuous current of 100 milliamperes and of detecting discontinuities in this current >1 microsecond.

5.0 Procedure

5.1 Calibration

5.1.1 The shock machine shall be set up to provide an acceleration waveform conforming to Table I and Figure 3 or 4 as specified in the individual connector specification; if a specific waveform is not specified, the terminal peak sawtooth waveform shall be used.

5.1.2 The fixtured test sample or a suitable dummy load shall be mounted on the shock machine during the calibration procedure. Any dummy load shall have the same mass and center of gravity as that of the test sample and shall be fixtured in a similar manner (a reject connector provides an ideal dummy load).

¹For half-sine pulse of less than 3 milliseconds duration, it is not required that the envelope fall within the tolerances specified in Figure 3. The faired (smoothed) amplitude of the measured pulse shall be within ± 20 percent of the ideal amplitude. The measured duration shall be within ± 15 percent of the specified duration. The velocity change of the faired pulse shall be within $\pm 10\%$ of the ideal change. The duration of the pulse shall be measured at the 0.1A point on the pulse; the base line duration of the pulse shall be calculated as the duration measured at the 0.1A point divided by 0.94. (For tolerance limits for measuring system frequency response see Figure 5.)

NOTE: The oscillogram should include a time about 3D long with the pulse located approximately in the center. The integration to determine velocity change should extend from 0.4D before the pulse to 0.1D beyond the pulse. The acceleration amplitude of the ideal half sine pulse is A and its duration is D. Any measured acceleration pulse which can be contained between the broken line boundaries is a nominal half sine pulse of nominal amplitude A and nominal duration D. The

Number 3.8	Subject Mechanical Shock, Connectors	Date 7/75
Revision A		

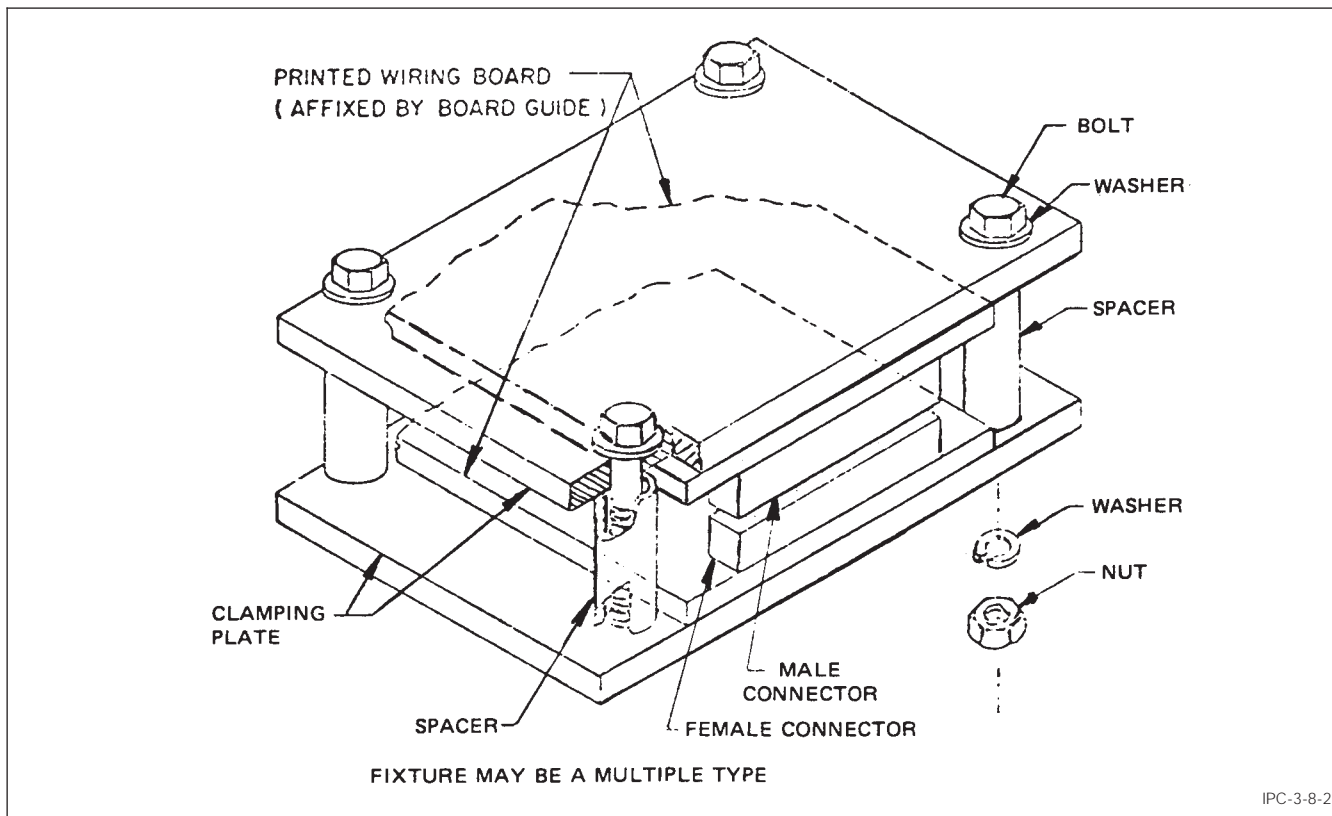

Figure 2 Parallel Connector Fixture (Suggested)

Table I
Test Conditions

Test Condition	Peak Acceleration A-Gravity Units	Nominal Duration D-Milli-seconds	Waveform	Velocity Change Vi (G-MS)
A	50	11	Half-sine	350.30
B	75	6	Half-sine	286.62
C	100	6	Half-sine	382.16
D	500	1 ¹	Half-sine	318.47
E	1000	0.5 ¹	Half-sine	318.47
F	5000	0.5 ¹	Half-sine	477.70
G	50	10	Sawtooth	250.00
H	75	6	Sawtooth	225.00
I	100	6	Sawtooth	300.00

velocity-change associated with the measured acceleration pulse is V.

5.1.3 The monitoring transducer shall be mounted on the test fixture immediately adjacent to the test specimen or dummy load. Two consecutive shock applications to the calibration load shall produce acceleration waveforms that fall within the appropriate tolerance envelope; in addition, graphical integration of each recorded pulse shall indicate a velocity change within 10% of the value specified in Table 1.

5.2 Test

5.2.1 The dummy load shall be replaced with the actual test sample.

NOTE: If all conditions, other than this substitution, remain the same, the resulting test waveform shall be considered satisfactory even though it may not conform to Figures 3 or 4, as appropriate.

IPC-TM-650		
Number 3.8	Subject Mechanical Shock, Connectors	Date 7/75
Revision A		

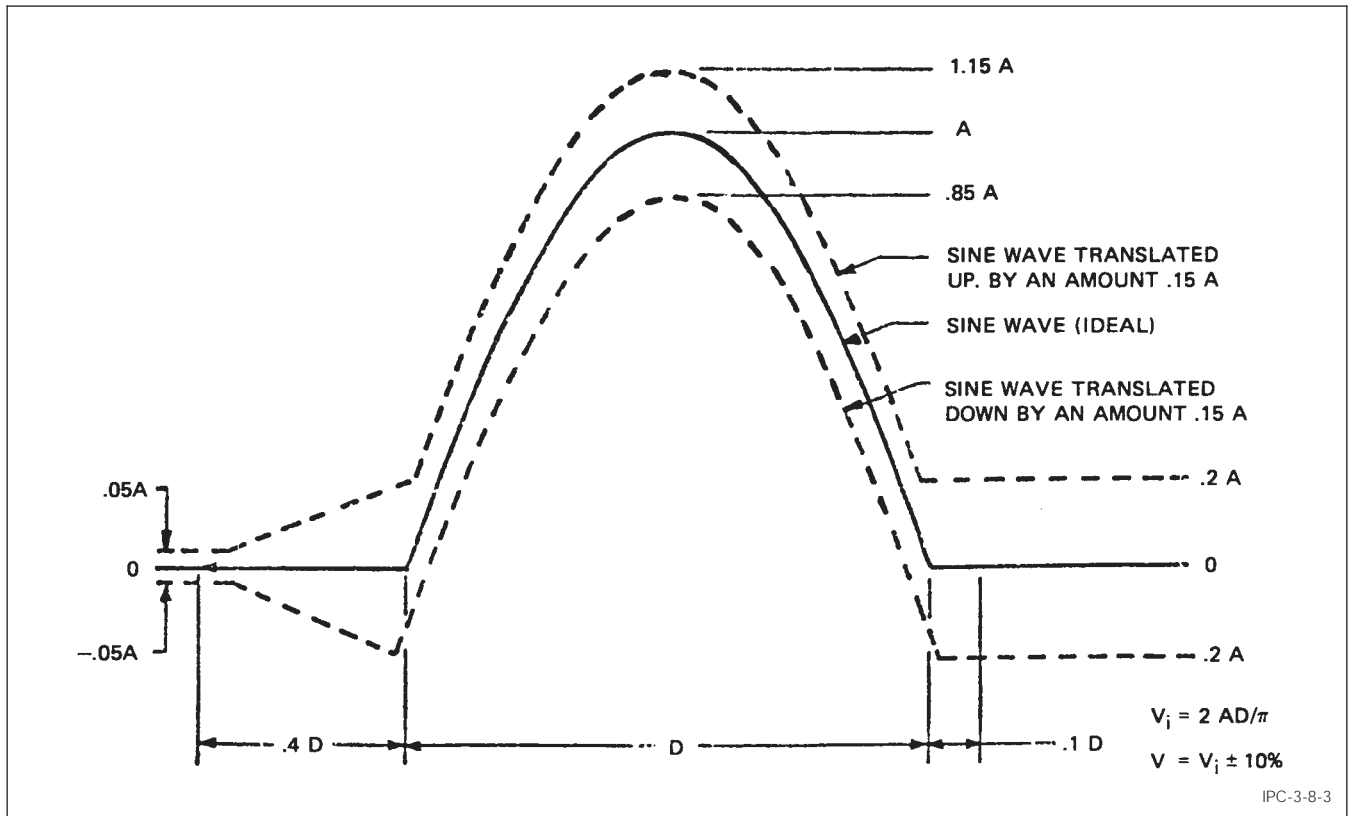

Figure 3 Tolerances for Half Sine Shock Pulse

5.2.2 The test sample shall be connected to the discontinuity monitor and a minimum current of 100 milliamperes shall be established in the series circuit comprising all contacts of the test sample.

5.2.3 The test sample shall be subjected to three (3) shocks in each direction along each of three (3) orthogonal axes (18 shocks total). During and after the application of each shock, the contacts shall be monitored for discontinuities in excess of 1 microsecond.

NOTE: The oscillogram should include a time about 3D long with the pulse approximately in the center. The integration to determine the velocity change should extend from 0.4D before the pulse to 0.1D beyond the pulse. The peak acceleration,

magnitude of the sawtooth pulse is P and its duration is D. Any measured acceleration pulse which can be contained between the broken line boundaries is nominal terminal-peak sawtooth pulse of nominal peak value, P, and nominal duration, D. The velocity-change associated with the measured acceleration pulse is V.

6.0 Notes

6.1 Acceptance criteria shall be established in terms of one, or any combination, of the following:

- A. Loss of continuity during or after any imposed shock.
- B. Mechanical damage,

IPC-TM-650		
Number 3.8	Subject Mechanical Shock, Connectors	Date 7/75
Revision A		

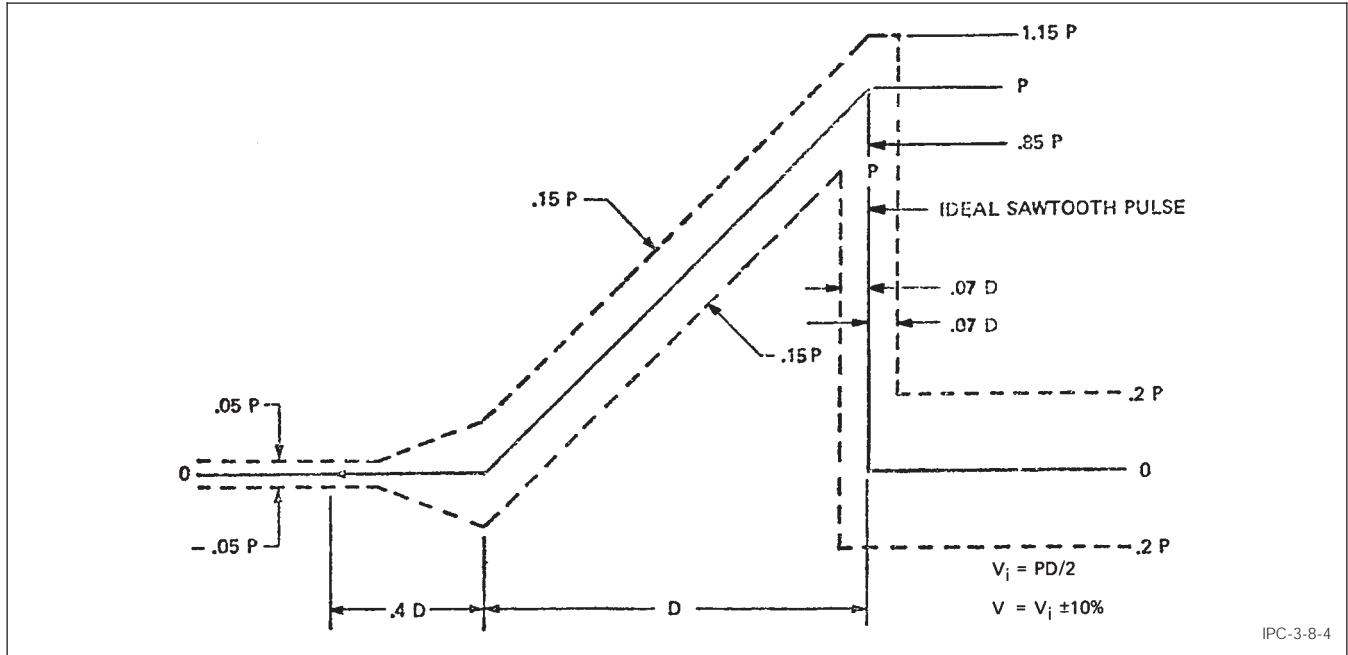

Figure 4 Tolerances for Terminal-Peak Sawtooth Shock Pulse

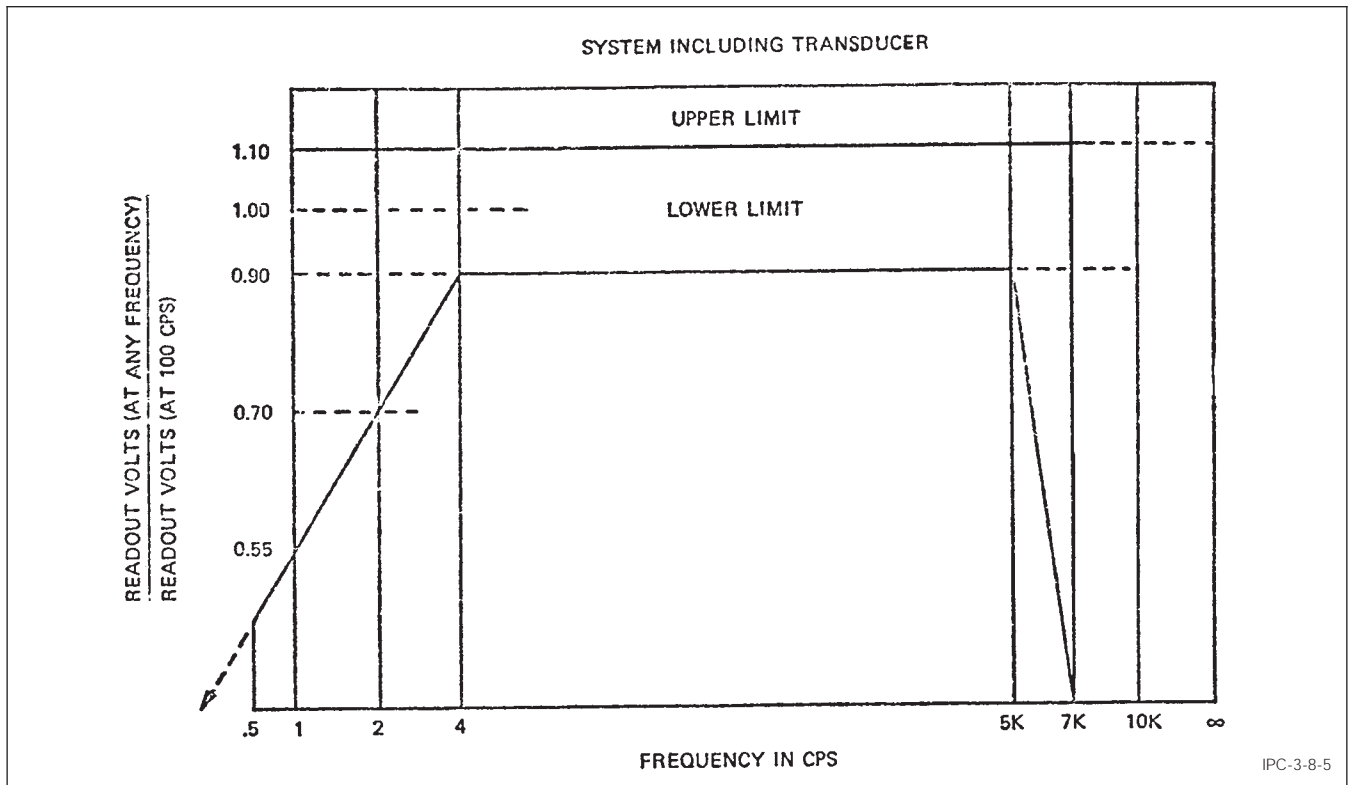

Figure 5 Tolerance Limits for Measuring System Frequency Response