



IPC-TM-650 TEST METHODS MANUAL

1 Scope This test method is to be used for the evaluation of hand soldering tools under a simulated heavy load such as that presented by PWBs with abnormally thick ground or power planes. Separate test methods (IPC-TM-650, Methods 2.4.37 and 2.4.37.1) are provided for evaluation of tools under normal operating conditions. The purpose of this test method is to provide a means by which hand soldering tools may be evaluated under a standard controlled set of conditions. This method may be used to either evaluate a single tool's performance or for comparison of several tools.

Note: Tip geometry, mass, contact area (working face), contact angle, and idle temperature can significantly skew the test results.

2 Applicable Documents

J-STD-004 Requirements for Soldering Fluxes

J-STD-006 General Requirements and Test Methods for Soft Solder Alloys and Fluxed and Nonfluxed Solid Solders for Electronic Soldering Applications

IPC-TM-650 Test Methods Manual

2.4.37 Evaluation of Hand Soldering Tools for Terminal Connections

2.4.37.1 Evaluation of Hand Soldering Tools for Printed Wiring Board Applications

3 Test Specimen The test specimen shall be a square, solder-plated, copper coupon, 1.58 mm thick, as listed in Table 1.

4 Equipment/Apparatus

4.1 Solder The solder shall be flux-cored wire per J-STD-006. The alloy shall be composition Sn60/Pb40 or Sn63/Pb37. The core shall be nominally 2.2% by weight type F(RA) or D(RMA). The wire size shall be 0.8 mm.

4.2 Workpiece The workpiece shall be an instrumented, square, solder-plated, copper coupon(s) mounted in or on a thermally insulated surface.

4.3 Fixture The coupon shall be held solder side up in or on a thermally insulated surface that will not represent a thermal load to the coupon(s) under test. A thermally insulative covered laboratory tile or screen should be adequate.

Number 2.4.37.2	
Subject Evaluation of Hand Soldering Tools On Heavy Thermal Loads	
Date 7/93	Revision
Originating Task Group N/A	

Note: Dimensions listed are 1.27 mm. The bottom side of the coupon may be plated with nickel to aid thermocouple attachment.

4.4 Thermocouple Wire The thermocouple wire shall be insulated Type J or K, as required by the selected test equipment. The wire size shall be 30 gauge. The working junction shall be formed by welding.

4.5 Data Recorder Test results shall be recorded on a data or chart recorder capable of resolving $\pm 2.8^{\circ}\text{C}$ and ± 1 second of time. The normal response time shall be 10 cps or better.

5 Procedure

5.1 Preparation of Workpiece Prepare the workpiece in the following manner:

5.1.1 Place bare copper coupon(s) on a hot plate or other suitable surface. The temperature of the hot plate must be set at a temperature sufficient to achieve reflow of solder.

5.1.2 Coat the test surface with solder conforming to 4.1.

5.1.3 Clean the surface of any flux residue to ensure that excessive amounts of solder have not been added.

[Optional] Plate the surface opposite the test surface with nickel to aid thermocouple attachment.

5.1.4 Weld or imbed the thermocouple to the test coupon(s) at a point 2/3 the distance from the center of the coupon in the direction of one of the corners (see Figure 1).

Note: In Figure 1, A is defined as half the length of the diagonal.

5.1.5 Mount the coupon(s), solder side up, in or on the fixture to be utilized during the test.

5.2 Preparation of the Soldering Tool Tip A thermocouple shall be attached to the tip(s) to be used in the test. This attachment shall be to the tip face opposite the working face. The attachment to the tip can either be done by drilling a small hole in the tip, nominally 6.85 mm back from the tip

Number 2.4.37.2	Subject Evaluation of Hand Soldering Tools On Heavy Thermal Loads	Date 7/93
Revision		

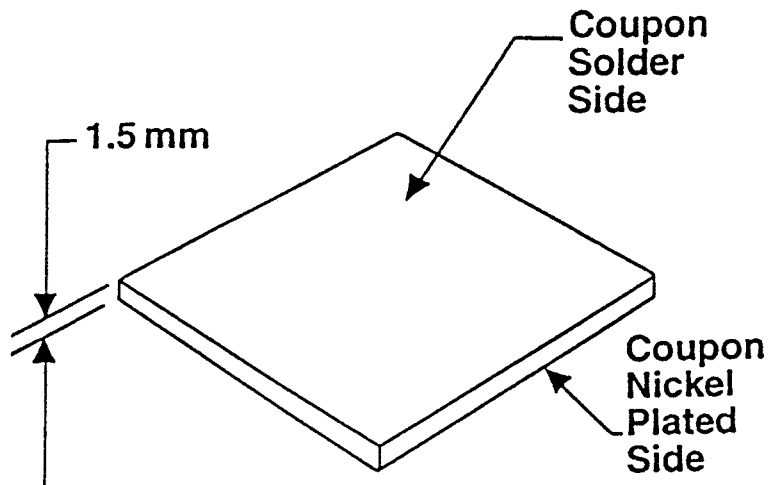

IPC-2-4-37-2-1

Type	Specimen Size	Edge Dimension*
I	Small	19 mm
II	Medium	25 mm
III	Large	32 mm

Table 1 Thermocouple Placement

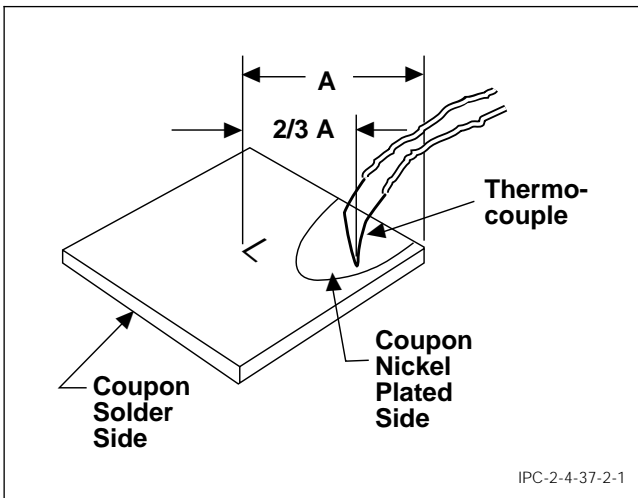

IPC-2-4-37-2-1

Figure 1 Thermocouple Placement

end, inserting the thermocouple wire and securing it with a small copper wedge, or by welding the thermocouple directly to the tip, also nominally 6.85 mm back from the tip end, but not on the tinned surface of the tip (see Figure 2). Once the thermocouple wire is attached to the tip, the wires leading from the junction shall be taped to the handle to prevent damage.

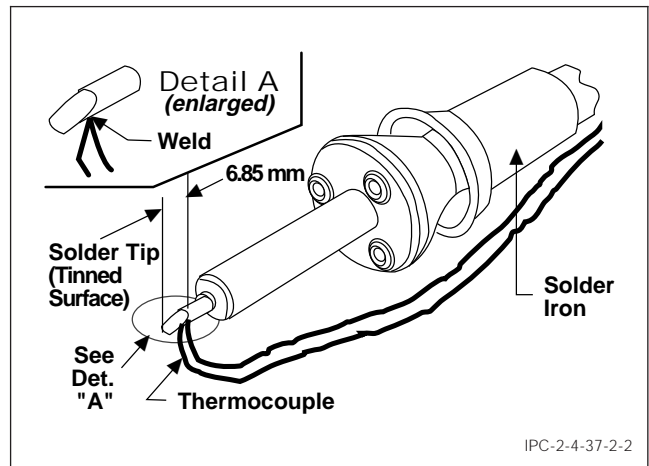

IPC-2-4-37-2-2

Figure 2 Tip Instrumentation

5.3 Test Preparation The workpiece shall be secured such that it will not move during soldering. The workpiece and the soldering tool thermocouple leads shall be attached to the data recorder. The recorder shall be properly zeroed or adjusted for correct reading.

5.4 Test A—Single Coupon Evaluation

IPC-TM-650		
Number 2.4.37.2	Subject Evaluation of Hand Soldering Tools On Heavy Thermal Loads	Date 7/93
Revision		

5.4.1 Set the desired temperature on adjustable irons and record the idle temperature. Record the temperature of non-adjustable irons. To combine adjustable and non-adjustable irons on the same test run, the adjustable irons should be set at the temperature of the non-adjustable irons. Irons must idle within 11°C of one another.

5.4.2 (Optional) Apply a drop of D or F flux conforming to J-STD-004 to the coupon at the center point where the soldering tool will be applied.

5.4.3 Start the data recorder.

5.4.4 The soldering tool tip shall be wiped and prepared in the best commercial practice. Apply fresh solder to the contact surface area of the tip to provide a good solder heat bridge.

5.4.5 Place the contact area (working face) of the tip on the center of the coupon under test and record the time required to bring the test coupon to a predetermined temperature within the range of 190°C to 260°C.

5.4.6 Remove the soldering tool to its standby holder. Do not turn off the data recorder until the soldering tool has recovered to its idle temperature.

The test coupon may be used for successive testing. Prior to further use, the coupon must have any excess solder removed along with any flux residue. The coupon must be allowed to cool to ambient room temperature prior to any subsequent testing.

5.5 Test B—Dual Coupon Evaluation

5.5.1 On an adjustable soldering tool, select and record the desired idle temperature. On a non-adjustable tool, record the idle temperature. To combine adjustable and non-adjustable irons on the same test run, the adjustable irons should be set at the temperature of the non-adjustable irons. Irons must be within 11°C of one another.

5.5.2 (Optional) Apply a drop of D or F flux conforming to J-STD-004 to the coupons at the center point where the soldering tool will be applied.

5.5.3 Start the data recorder.

5.5.4 The soldering tool tip shall be wiped and prepared in the best commercial practice. Apply fresh solder to the contact surface area of the tip to provide a good solder heat bridge.

5.5.5 Place the contact area (working face) of the tip on the center of the first coupon under test and record the time required to bring the test coupon to a predetermined temperature within the range of 190° to 260°C. The two coupons shall be thermally isolated from each other.

5.5.6 Immediately (within two seconds) place the soldering tool on the center of the second coupon under test and record the time required to melt the solder on the entire surface of the coupon.

5.5.7 Remove the soldering tool to its standby holder. Do not turn off the data recorder until the soldering tool has recovered to its idle temperature.

5.5.8 The test coupons may be used for successive testing. Prior to further use, the coupons must have any excess solder removed along with any flux residue. The coupons must be allowed to cool to ambient room temperature prior to any subsequent testing.

5.6 Reporting Table 2 lists the suggested reporting requirements.

6 Notes The temperature range identified in 5.4.5 and 5.5.5 is given so that an individual can select the predetermined temperature closest to the individual user requirements.

IPC-TM-650		
Number 2.4.37.2	Subject Evaluation of Hand Soldering Tools On Heavy Thermal Loads	Date 7/93
Revision		

Table 2 Copper Coupon Test Data

Tool No.	Idle Temp °C	Coupon Type I,II,III	Time to Predetermined Temperature Coupon 1	Workpiece Temperature at Predetermined Temperature	Solder Tool Temperature at Predetermined Temperature	Time to Predetermined Temperature Coupon 2	Workpiece Temperature at Predetermined Temperature	Solder Tool Temperature at Predetermined Temperature	Recovery Time
1									
2									
3									
4									
5									
6									
7									
8									
9									
10									
11									
12									
13									
14									
15									

Date of Tests:

Company Performing Tests:

Technician Performing Tests: